



# WEBYTZ

24  
25

Published on June 2025

**Shri. ASHOK KUMAR MUNDRA**  
Secretary

**Dr.S. SANTHOSH BABOO**  
Principal

## FACULTY MEMBERS OF THE DEPARTMENT

**Dr. T. SANTHANAM**  
Associate Professor & Head of the department

**Dr. T. VELMURUGAN**  
Associate Professor

**Dr. S. SANTHOSH BABOO**  
Principal

**Dr. R. ANANDHI**  
Assistant Professor

**Dr. T. SRIDEVI**  
Assistant Professor

**Ms. A. S. THENMOZHI**  
Assistant Professor

**Dr. M.P. SUKASSINI**  
Assistant Professor

**Dr. S. DEEPALAKSHMI**  
Assistant Professor

## EDITORIAL TEAM

**Ms. A. S. THENMOZHI**  
Assistant Professor

## EDITORIAL COMMITTEE

**S. LAKSHMI PRATHA**  
I MCA Student

**GOWTHAM**  
I MCA Student

**MURALEESWARAN M. K**  
I MCA Student

**VINOTHINI J. A**  
I MCA Student

## Message from the Secretary's Desk



I am delighted to learn about the release of the "WeBytz" newsletter by the MCA Department, which aims to feature the department's activities. I anticipate that this newsletter will serve as a platform to showcase the accomplishments and efforts of both faculty and students. Additionally, I have confidence that the students and staff of the department took advantage of this opportunity to test and enhance their intellectual skills, reaching a diverse readership. My congratulations go to the editorial team, staff, and the students of the MCA Department for the successful launch of this newsletter.

## Message from the Principal's Desk



It brings me great joy and satisfaction as the Principal of D.D.G.D.V.C to announce the annual release of the "WeBytz" newsletter by the Department of MCA. This publication serves as a valuable platform to showcase the noteworthy achievements of students in curricular, co-curricular, and academic domains. I am optimistic that the newsletter will aptly reflect a comprehensive overview of the department's performance and its significant contributions to the overall development of our students. I extend my sincere congratulations to the dedicated editorial board for their tireless efforts in bringing this informative newsletter to fruition.

## Message from the HOD's Desk



The Department of MCA is one of the pioneering departments of this institution. We offer our students a good educational experience with the latest requirements in IT as their academic subjects. The department also conducts various programs to enrich the technical skills of the students. It is indeed my great pleasure that our department is publishing the annual newsletter "WeBytz" inscribing every aspect of departmental activities and events held from the academic year 2024–2025. The newsletter aims to bring into view various happenings in the department. I congratulate the editorial board who has taken this initiative for publishing this newsletter.



## ABOUT DEPARTMENT

The Department of MCA was established in 1987 with the aim of creating a conducive ambiance for learning management and career-oriented subjects. Over the years, curriculum has been fine-tuned by introducing specialized subjects aligned with industry requirements, aiming to impart knowledge in the field of information technology and current trends.

### Mission

Organise workshops at regular intervals to bridge the gap between academia and industry.

- Enable students to be industry-ready by developing a state-of-the-art curriculum in tune with industry requirements.
- Facilitate students to excel in the challenging scenario by providing the necessary skill set.
- Make students understand the concepts using innovative teaching material.

### Vision

- Empower every student to be innovative, creative, and productive in the domain of computer science by imparting quality education, developing skills, and inculcating human values.

### Objective

The main objective is to make the students technically talented in the information technology field. The department has collaborated with IIT Mumbai's Spoken Tutorial Project, offering certificate courses to help students gain exposure to leading IT tools and languages, which are integral parts of the curriculum for earning credits. Students are advised to enroll in online MOOC courses to enhance their knowledge. The hallmark of the department is the regular update of the curriculum in consultation with IT experts on the Board of Studies (BOS) to introduce current technologies prevailing in the market. This ensures that students can upgrade their skills for employment.

# DEPARTMENT ACTIVITIES

## WORKSHOP ON END-TO-END WEB DEVELOPMENT

on 26.07.24



The attendees gained a comprehensive overview of modern full-stack development practices, exploring key technologies such as front-end frameworks, backend services, databases, and deployment strategies. They also learned about best practices, real-world use cases, and how to stay up-to-date in the rapidly evolving tech landscape.

It emphasized the importance of understanding each component of the stack and how they interact to build scalable and efficient applications.

By mastering the integration between client-side and server-side technologies, developers can create more robust, maintainable, and user-friendly solutions.

Students were encouraged to continue learning and experimenting with these technologies to stay current in a rapidly evolving field.

They were inspired to adopt a mindset of continuous improvement by engaging with online learning platforms, attending tech meetups and webinars, and collaborating on real-world projects. Emphasis was placed on building a strong foundation, staying curious, and being open to new tools and frameworks, as adaptability and lifelong learning are essential traits for success in the tech industry.



# WORKSHOP ON GENAI-PROMPT ENGINEERING

on 29.07.24

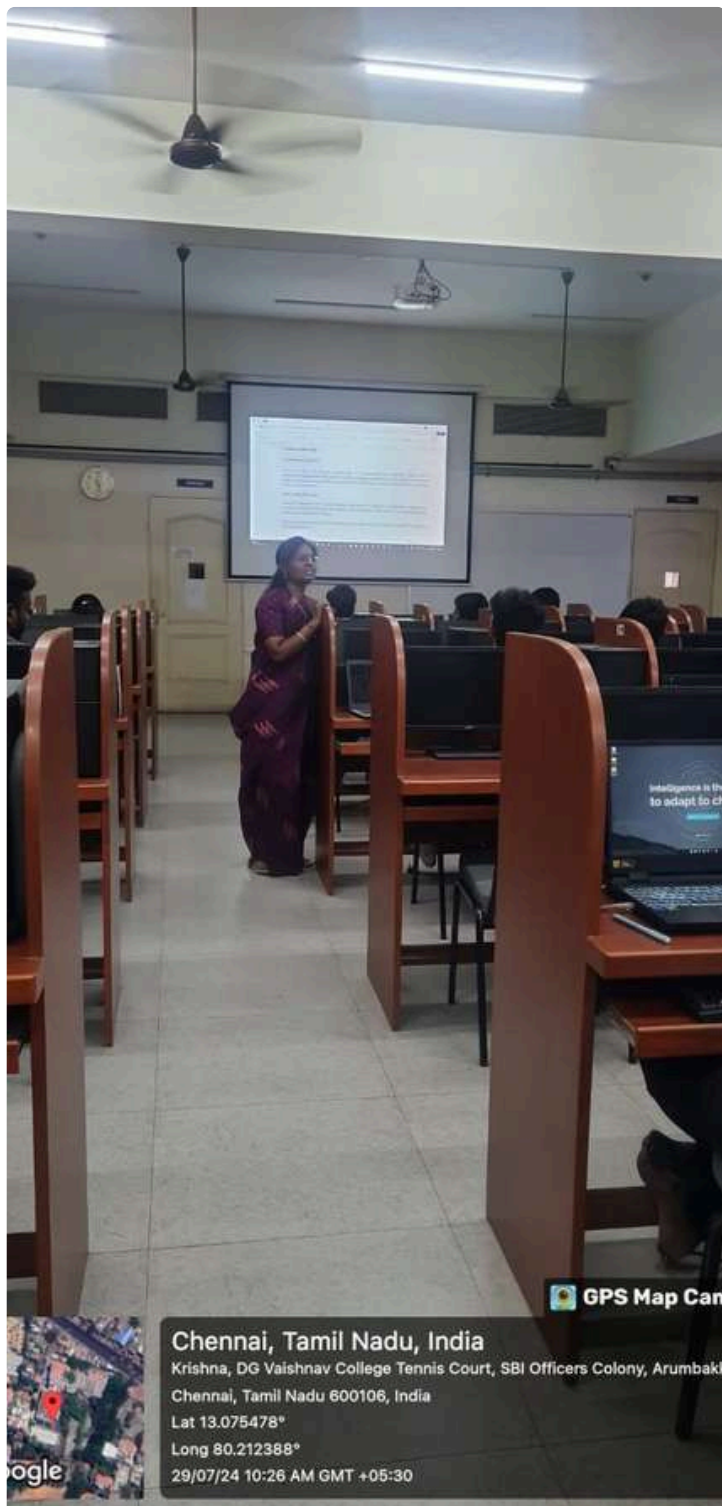

It covered key principles of prompt engineering, along with the technological foundations of ChatGPT like machine learning and deep learning.

Participants gained insights into how large language models interpret prompts, generate human-like responses, and the role of neural networks in enabling contextual understanding and language generation.

It highlighted practical applications for including keywords to retrieve relevant output from ChatGPT.

The session demonstrated how well-structured prompts can influence response accuracy, and provided real-world examples where keyword optimization led to more precise, task-specific outputs. It encouraged the students to integrate these insights into their academic work confidently.

They were motivated to apply prompt engineering techniques in research, assignments, and projects to improve productivity and creativity. The session also emphasized developing critical thinking when using AI tools, enabling students to combine technical knowledge with thoughtful application in their studies.

Students were encouraged to continue learning and experimenting with these technologies to stay current in a rapidly evolving field. They were inspired to adopt a mindset of continuous improvement by engaging with online learning platforms, attending tech meetups and webinars, and collaborating on real-world projects. Emphasis was placed on building a strong foundation, staying curious, and being open to new tools and frameworks, as adaptability and lifelong learning are essential traits for success in the tech industry.

# WORKSHOP ON DATA VISUALIZATION USING POWER BI

on 22.08.24

Students gained knowledge on Data Visualization.

They explored how to represent complex data in clear, meaningful visuals such as charts, graphs, and dashboards, which help in better analysis and decision-making.

Students learned fundamentals of Power BI and its components.

This included understanding Power BI Desktop, Power BI Service, data sources, DAX functions, and the report-building interface.

Students gained practical knowledge on Power BI.

Through hands-on exercises, they practiced importing data, creating visual reports, and sharing insights—bridging the gap between theory and real-world application.



# WORKSHOP ON SOCIAL MEDIA ANALYSIS USING ML

on 28.08.24



Understanding Sentiments: Learn to analyze if social media posts are positive or negative. Students explored how sentiment analysis helps businesses and researchers gauge public opinion, brand perception, and emotional trends through text data.

**Finding Trends:** Discover how to spot and follow emerging topics on social media.

They learned how to identify viral content, hashtags, and key conversations, enabling data-driven insights into audience interests and behavioral shifts.

**Using Tools:** Gain hands-on experience with machine learning tools for better data analysis.

Participants worked with user-friendly platforms and Python libraries to apply machine learning techniques, making complex data analysis more efficient and insightful.

## GUEST LECTURE ON A ROADMAP FROM CURRICULUM TO INDUSTRY

on 04.01.25



Gained ideas about data analysis and data science jobs and how to choose internships wisely:

Learned about the various roles in data analysis and data science, including the skills required for each. Also understood how to evaluate internship opportunities based on personal interests, career goals, and learning outcomes to make informed decisions.

Learned ways to overcome social anxiety and interview fear:

Discovered practical strategies such as breathing exercises, mock interviews, and positive self-talk to build confidence. Also learned the importance of preparation and mindset in reducing anxiety during social interactions and professional interviews.

Received practical tips on choosing a suitable career role:

Understood how to align personal strengths, values, and interests with potential career paths. Also gained insights into researching different roles, seeking mentorship, and setting short-term and long-term career goals for better decision-making.

# GUEST LECTURE ON UHV - EMPATHY IN COMMUNICATION

on 25.01.25

## Stronger Relationships:

Empathetic listening fosters trust and mutual respect, deepening personal and professional connections. When individuals feel genuinely heard, it builds a foundation of openness and honesty, which strengthens bonds over time and encourages meaningful communication. This active engagement also reduces misunderstandings and helps create a safe space where people feel comfortable sharing their thoughts and feelings. Over time, this consistent emotional availability contributes to more loyal and lasting relationships.

## Improved Understanding:

By truly understanding the speaker's emotions and perspectives, we are better equipped to respond thoughtfully and resolve misunderstandings. This not only helps in avoiding unnecessary conflicts but also promotes clearer communication and more effective problem-solving in both personal and team settings. Empathetic listening allows us to look beyond words and tune into the speaker's intent and emotional state, resulting in more compassionate and informed responses. It encourages mutual learning and a deeper appreciation for different viewpoints.

## Increased Emotional Support:

When people feel heard and validated, it creates a supportive environment that can lead to emotional healing and a sense of belonging. Empathetic listening assures others that their feelings matter, which can boost their self-esteem, reduce stress, and improve overall well-being. It also nurtures emotional resilience by letting individuals know they are not alone in their experiences. This sense of connection can be especially powerful during challenging times, offering comfort and encouragement when it's needed most.

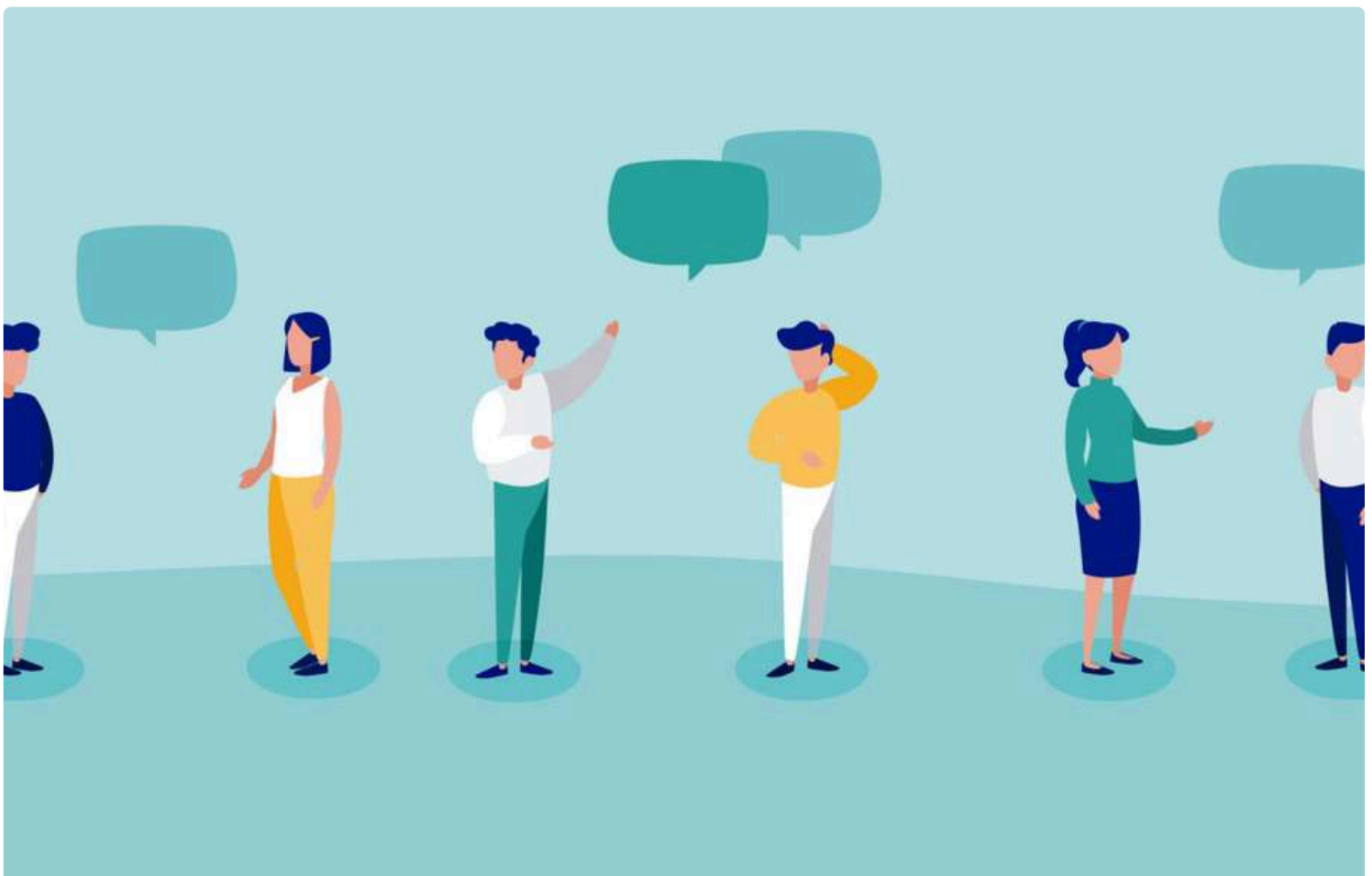

# GUEST LECTURE ON BUILDING A STRONGER TECHNOLOGY DRIVEN CAREER

on 29.01.25

The lecture will address common challenges such as interview fear and social anxiety, offering simple yet effective strategies to boost confidence in professional settings. In addition, students received a clear roadmap for staying relevant in a fast-evolving tech landscape through continuous learning, adaptability, and strategic goal-setting. Real-world examples, personal experiences, and industry tips shared to students a realistic view of what it takes to stand out in the competitive world of technology. By the end of the session, students equipped with both the inspiration and the practical tools needed to take charge of their tech careers with clarity and confidence.

Students gained knowledge on the importance of recognizing gender biases and stereotypes, which are often deeply ingrained in both society and organizational culture. They learned how these biases can subtly influence hiring decisions, team dynamics, and career progression, emphasizing the need for conscious awareness and proactive behavior in creating inclusive environments.

Students understand the challenges faced by different genders in the workplace, including wage gaps, leadership disparities, and unconscious biases. Through discussions and real-world examples, they explored how these issues impact professional growth, job satisfaction, and overall workplace equity, along with strategies to promote fairness and equal opportunity.

Students gained insight into the gender-sensitive policies implemented in organizations through case studies, which illustrated how progressive companies are addressing gender issues.

These case studies provided a practical understanding of how policies such as equal pay audits, mentorship programs, flexible work arrangements, and inclusive hiring practices can foster a more equitable and supportive workplace for all genders.



# GUEST LECTURE ON GENDER SENSITIZATION

on 07.02.25



Students gained knowledge on the importance of recognizing gender biases and stereotypes.

students understand the challenges faced by different genders in the workplace, including wage gaps, leadership disparities and unconscious biases.

Students gained insight knowledge on the gender sensitive policies implemented in the organization through case studies

# WORKSHOP ON IOT

on 15.02.25

Students get hands-on experience with real-world IoT devices and platforms such as Arduino, Raspberry Pi, various sensors, and cloud-based tools. This practical exposure allows them to explore how embedded systems and connected technologies work together to form intelligent systems. They learn to build functional prototypes that sense, process, and transmit data in real time, which greatly enhances their technical confidence. Students also enhance their capabilities in coding, hardware interfacing, data collection, analysis, and communication protocols. They gain practical insight into how data flows from a sensor to the cloud, and how this data can be used for automation, monitoring, or decision-making.

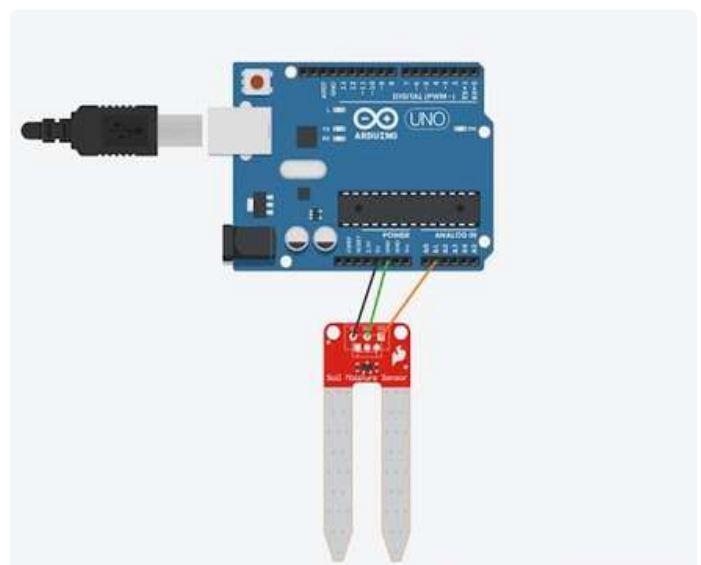

# GUEST LECTURE ON TECHNOLOGY IN SBI

on 04.03.25

Students gained awareness on Cyber Security Measures and Fraud Prevention:

Through interactive sessions and real-life case studies, students developed a strong understanding of the importance of cyber security in the modern banking ecosystem. They learned about common online threats such as phishing, identity theft, and digital scams, as well as the proactive steps banks and customers can take to safeguard sensitive information. This knowledge helps them become more responsible digital citizens and prepares them for roles where data security is crucial.

Students gained knowledge on Technology in SBI Digital Services, YONO App, and Customer Experience:

The session provided valuable insights into the technological innovations driving SBI's digital banking services, especially through the YONO (You Only Need One) platform. Students explored how the app integrates various banking services, investment options, and lifestyle needs into a single user-friendly interface. They also learned about the role of user interface design, backend support, and real-time data processing in enhancing customer satisfaction and delivering a seamless digital experience.

Students understood the idea behind the Complaint Resolution and Customer Redressal Mechanisms:

By examining the end-to-end process of how customer complaints are handled in a large banking organization like SBI, students gained a practical perspective on service management and customer relationship practices. They learned about the different channels available for grievance submission, escalation procedures, and timelines for resolution. The session emphasized the importance of transparency, accountability, and efficiency in building trust and maintaining customer loyalty in the financial sector.



# VALUE ADDED COURSE



## Mern Full Stack Course by Illustro

The department has initiated a 60-hour certificate program focused on Mern Full Stack Development, specifically tailored for second year MCA students. The program is designed to provide both foundational knowledge and hands-on experience in full-stack web development, equipping students with industry-relevant skills. Facilitated by Inlustro, a leading tech training partner, the course covers a comprehensive range of topics including front-end and back-end technologies, database integration, version control systems, and deployment strategies. Emphasis is also placed on industry best practices, coding standards, and real-world project development, ensuring participants are job-ready and aligned with current market demands.

## Java Full Stack Course by Illustro

The department has initiated a 60-hour certificate program focused on Java Full Stack Development, specifically designed for first-year MCA students. This initiative aims to equip students with both conceptual understanding and practical experience in full-stack web development. Facilitated by Inlustro, the program comprises a series of sessions that cover key front-end and back-end technologies such as React JS, Bootstrap, Java, and Spring Boot. In addition to technical training, the program emphasizes industry best practices, modern development workflows, and collaborative project work—preparing students to meet the demands of today's tech-driven job market.

# PLACEMENTS

S:NO	NAME	YEAR	COMPANY
1	MADHUMITA G	II MCA	PRESIDIO
2	KARANKUMAR G	II MCA	DATA ACES
3	JOFIN N S JEEN	II MCA	DATA ACES
4	DITI V JAIN	II MCA	DATA ACES
5	SWATHY S	II MCA	COMCAST
6	MONICKA M	II MCA	AGNIKUL COSMOS
7	SWEDHA .V	II MCA	MINDIT
8	SHARMILI R S	II MCA	SKILLSKAPES
9	PREMALATHA V	II MCA	BILIGHT
10	SIMPSON J	II MCA	CHIMERTECH
11	HANSIKA PRIYA A A	I MCA	BILIGHT(INTERN)
12	KARTHICK D	I MCA	BILIGHT(INTERN)
13	DHEIVEEKA NACHIYAR P	I MCA	BILIGHT(INTERN)
14	SOWMIYA M	I MCA	BILIGHT(INTERN)
15	HARSHINI S	I MCA	BILIGHT(INTERN)
16	KRISHNAVENI E G	I MCA	DATA ACES(INTERN)



# CO-CURRICULAR ACTIVITIES



**Shri Krishnaswamy College for Women - OVERALL WINNER - Tech Horizon '25**

I MCA students Lakshmi Pratha S and Dheiveeka Nachiyar P secured Second Place in A Minute Film. Hansika Priya A A and Amrath Fathima Shifa N secured Second Place in Code Puzzle and Third Place in Scavenger Hunt.



**Madras Christian College - First Place with 2K cash prize - Designing Ninjas**

Nithyakumar M and Srinivasan R of I MCA secured First Place in Designing Ninjas at MCC and won a cash prize of ₹2000.



**Guru Nanak College - First Prize - Paper Pinnacle and Tech Sync**

II MCA students Madhumita S and Dhanusgopi P secured First Place in both Paper Pinnacle and Tech Sync competitions, at JUNO 2025.



**Ethiraj College - OVERALL WINNER - Anvaya 2024**

I MCA students Poornesh S and Monicka M secured First Place in the Paper Prism competition, Monicka M and Thivya K G also bagged First Place in Waste to Wow, Diti V Jain earned First Place in the Shift Masters event, Madhavan A secured Second Place in Code Cracking, Reshma G and Thivya K G won Second Place in Byte Battle at Anvaya 2024



### Runner up in cricket at department sports meet

I MCA students Muraleeswaran M K, Dhanush Kumar R, Shareen Kumar J, Deepak Kumar R, Sakthivel S, Srinivasan M, and II MCA Students Yoganaswamy, Aravind, Simphson, Naveen, Nitish, and Gopi were the Runners-up in Cricket at the Department Sports Meet.



### Winners in badminton

I MCA students Surendar, Dhanush Kumar R, and Shriram M emerged as Winners in Badminton.

## SORTIFY: A VISUAL APPROACH TO UNDERSTANDING SORTING ALGORITHMS



**SORTIFY**  
SMART SORTING

An Intelligent Learning Companion for Students, Developers, and Visual Learners

Sortify is an Android mobile app that simplifies learning sorting algorithms through real-time animations. By visualizing sorting processes with dynamic bar movements, it bridges the gap between theory and practice, helping users easily understand how data is organized using various sorting techniques.

### Purpose of the Project

Sortify simplifies learning sorting algorithms by visualizing them with real-time bar animations, making it easier to understand data organization through different sorting techniques. Users can interact with the app, adjusting speeds and pausing to analyze each step in the sorting process.

### Tools and Technologies

Sortify is developed using Java for implementing core sorting logic and XML for designing a clean and responsive UI, all built within Android Studio.

The app uses RecyclerView with custom adapters to dynamically generate and manage the vertical bars representing array elements. Smooth animations are achieved through custom threading, allowing users to control sorting speed and pause/resume the process seamlessly.



## Visualization Mechanism

Each sorting algorithm is illustrated through animated bars of varying heights, representing data elements. Their positions change as sorting progresses, and the color coding enhances the understanding of each step:

- **Crimson:** Active comparison between bars.
- **Yellow:** Swapping elements in progress.
- **Green:** Elements that are sorted.
- **Blue:** Pivot elements in sorting algorithms like Quick Sort.
- **Violet:** Default unsorted bars before the algorithm begins.

Users can control the animation speed and pause the process to analyze each step, enabling a deeper understanding and retention of sorting algorithms.

## Algorithms Included

Sortify features six widely used sorting algorithms:

- Bubble Sort
- Insertion Sort
- Selection Sort
- Merge Sort
- Quick Sort
- Heap Sort

Users can select an algorithm from a dropdown menu and watch it operate on randomly generated bars, making it easier to observe and compare the logic and performance of each algorithm.

## Core Features and Learning Outcomes

Sortify features real-time animations of sorting steps, adjustable speed, pause/resume control, algorithm descriptions, and an integrated quiz. The responsive UI adapts to all screen sizes.

Users can grasp sorting algorithms, visualize performance, retain knowledge through animations, and apply concepts in real-world coding.

## Who It's For

Sortify is designed for a diverse audience, including computer science students studying data structures and algorithms, educators seeking interactive teaching aids, developers preparing for technical interviews, and tech enthusiasts curious about the inner workings of sorting algorithms. The app simplifies learning through intuitive visuals and clear explanations, making it an ideal tool for users at all levels to gain a deeper understanding of sorting techniques and their performance.

## Design Flow Visualization

The user interface utilizes LinearLayouts and RecyclerViews for flexibility and responsiveness.

Key screens include:

- **Home Screen:** Select algorithms and initiate sorting
- **Visualization Screen:** Display real-time sorting animations
- **Quiz Module:** Track user challenges and scores
- **Info Pages:** Provide algorithm explanations and app guidance

Each screen is designed for optimal usability, ensuring a seamless and engaging learning experience.

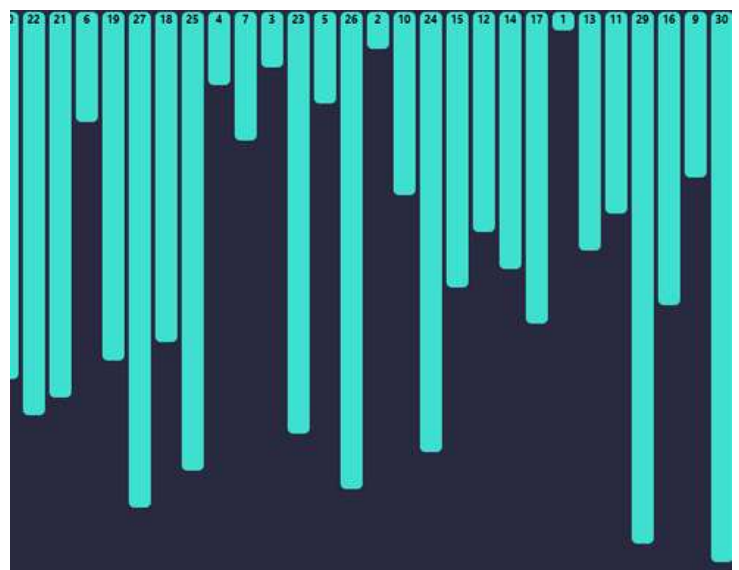

# Sorting Algorithms

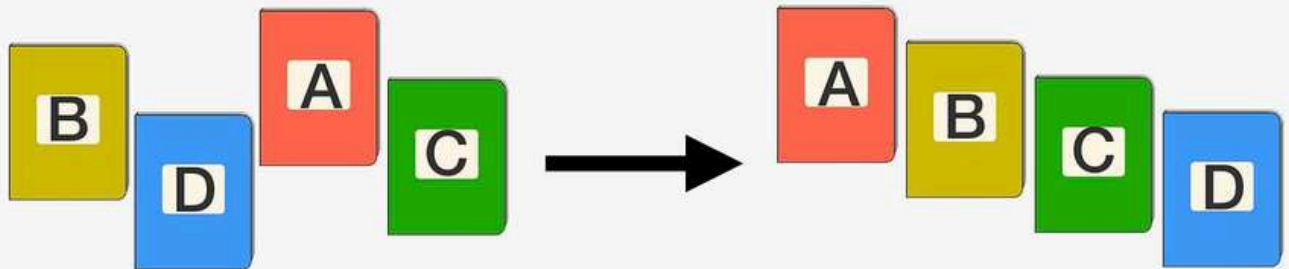

## Future Scope

Future updates of Sortify will introduce advanced algorithms like Radix Sort, Counting Sort, Shell Sort, Bucket Sort, and Tim Sort. Additional features such as performance comparison charts, dark mode, algorithm difficulty levels, and the ability to export sorting steps or quiz results are planned. These enhancements aim to make Sortify a more comprehensive, user-friendly, and powerful learning tool for mastering sorting algorithms.

By  
Krishnaveni E G  
Kavitha P  
I MCA

# FINANCIAL FORECASTING WITH LSTM: A DEEP LEARNING APPROACH

In recent years, Artificial Intelligence (AI) has gone from a futuristic concept to something we interact with every day. Whether it's helping us choose what to watch, making shopping recommendations, or supporting complex tasks like medical analysis, AI is becoming a key part of our daily lives and business processes.

Behind this shift are powerful tools like Machine Learning (ML) and Deep Learning. Among them, Long Short-Term Memory (LSTM) networks stand out for their ability to handle sequences of data—making them especially useful for tasks like predicting trends, understanding patterns, and supporting smarter decision-making in areas like finance.



## Understanding the Transition: ML to Deep Learning:

Machine Learning allows computers to recognize patterns and improve from experience without being explicitly programmed for every task. Deep Learning, a branch within ML, builds complex models using multilayered neural networks that mimic how humans process information and make decisions.





# Deep Learning

Your Guide to Financial Prediction with LSTM

## Recurrent Neural Networks: Giving AI a Sense of Memory

### Why RNNs Are Important

Recurrent Neural Networks (RNNs) are particularly well-suited for handling sequential or time-based data—think stock prices, speech, or written language. Their strength lies in their ability to retain context through loops in their architecture, enabling them to remember previous inputs. This makes RNNs valuable in areas such as:

- Forecasting time-series data
- Processing audio or text
- Tasks involving decisions based on sequences

### The Downside of RNNs

Despite their strengths, standard RNNs face difficulties with long-term memory due to what's known as the vanishing gradient problem. This issue limits their ability to hold onto older information in longer sequences, reducing their effectiveness in complex tasks.

### Solving Sequence Problems with LSTM Networks

Long Short-Term Memory (LSTM) networks were created to overcome the shortcomings of traditional RNNs. By incorporating specialized components like memory cells and gating mechanisms, LSTMs can selectively retain or forget information over time.

### How LSTM Works

LSTM networks use a unique structure with three gates:

- **Input Gate:** Regulates what new data enters the memory.
- **Forget Gate:** Decides what information should be removed.
- **Output Gate:** Determines what part of the memory to pass along.
- This architecture allows LSTMs to maintain relevant data over extended periods, avoiding the common pitfalls of standard RNNs. As a result, they're especially useful for tasks that involve long-term patterns, such as predicting financial trends or modeling language.

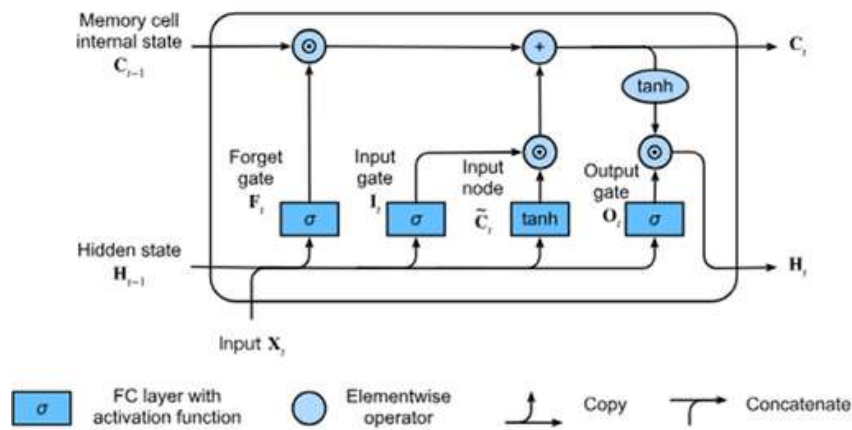

Symbol	Meaning
$\sigma$	Sigmoid activation function (output between 0–1, used for gates)
$\tanh$	Hyperbolic tangent activation (output between -1 to 1)
$\odot$ (elementwise operator)	Multiplication or addition done element-wise
$\oplus$ (plus symbol)	Element-wise addition of vectors
T-shaped junction	Concatenation of inputs
$\rightarrow$ (arrow)	Data flow
Copy symbol	Signal is duplicated and sent to multiple paths

## Putting It into Practice: The AI-Based Financial Planner

### About the Project

I built a web-based AI financial planning tool that helps users make better financial decisions through data-driven insights. The system integrates LSTM networks for forecasting and Random Forest models for classification, creating a hybrid solution for personal finance.

## How LSTM Works

### Core Features

- **Savings Forecasting:** Predicts future savings over a six-month horizon using LSTM.
- **EMI Calculator:** Computes loan payments based on inputs like principal amount and duration.
- **Investment Advice:** Applies Random Forest to suggest personalized investment strategies based on financial behavior and objectives.

## FINANCIAL PLANNER

This project helps you analyze your financial expenses and track savings goals while offering personalized investment suggestions. Let's get started!

Upload your financial expenses CSV file

Choose File Harlee.csv

Next

## FINANCIAL SUMMARY

A comprehensive overview of your financial performance, highlighting key metrics and insights to help you understand your current financial health.

### PROJECTED SAVINGS

Visualize your predicted savings over the upcoming months based on your current financial data and trends.

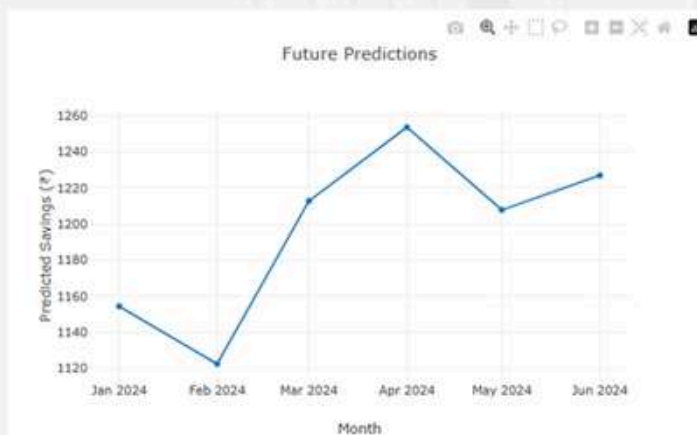

LSTM networks are revolutionizing how we work with sequential data—and financial applications are a prime example. By combining advanced deep learning with traditional ML techniques, it's possible to build intelligent financial tools that offer real value to users. As digital data grows, smart tools like the AI-Driven Financial Planner will play a vital role in helping people make well-informed financial decisions based on real-time insights.

By  
Harshini S  
I MCA

# AI-BASED SMART ENERGY MANAGEMENT SYSTEM

The Department recently launched a comprehensive 60-hour Certificate Program on Java Full Stack Development, specially designed for first-year MCA students. This initiative aimed to equip students with foundational knowledge and hands-on experience in full-stack web development, covering both front-end and back-end technologies. The program was conducted in collaboration with Inlustro, a reputed industry partner. As a testament to the students' enthusiasm and skills, our team proudly secured the Second Prize, along with a cash award of ₹7,500, showcasing their innovation and technical prowess.



Won second prize of cash ₹7500

### About the project:

The AI-Based Smart Energy Management System is a web-based solution designed to help businesses optimize their electricity usage and minimize energy waste. In response to the growing emphasis on sustainability and efficient energy practices, this platform leverages advanced AI algorithms to provide intelligent insights and automation.

It allows users to monitor, analyze, and control their energy consumption in real-time, ensuring smarter decision-making and enhanced operational efficiency. Through features like energy consumption forecasting, smart bill estimation, and automated appliance scheduling, the system promotes energy conservation and cost savings — empowering businesses to contribute toward a greener and more sustainable future.

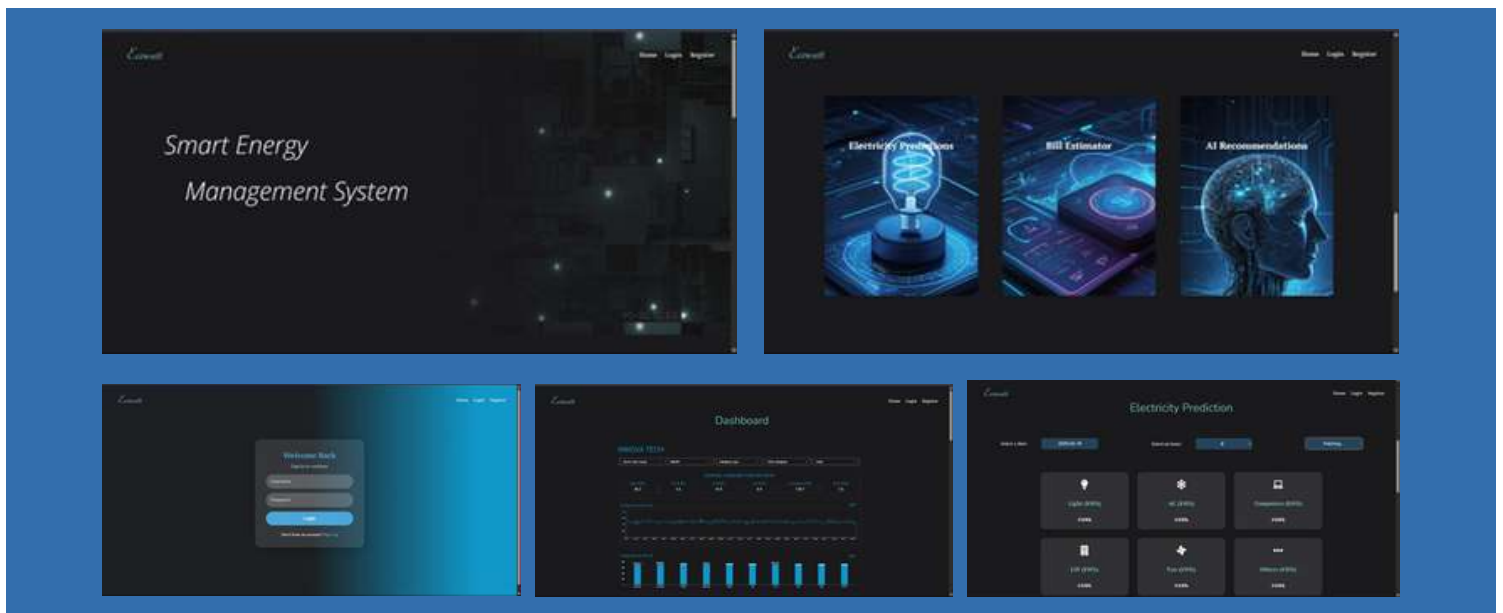

By  
Hansika Priya A A  
Amrath Fathima Shifa N  
Keerthika k  
Harini R  
I MCA

# POWER BI IN ACTION: UNLEASHING BUSINESS INSIGHTS WITH DATA VISUALIZATION

In today's data-driven era, organizations are increasingly leveraging Business Intelligence (BI) tools to turn raw data into actionable insights. Among the most powerful tools in this space is Power BI, developed by Microsoft. Power BI enables professionals to visualize data, track key metrics, and drive strategic decisions through dynamic dashboards and interactive reports.

Power BI is an advanced analytics and visualization platform that connects with multiple data sources—Excel, SQL Server, cloud services, and more—to transform data into coherent, visually immersive dashboards. Its drag-and-drop interface, built-in AI features, and real-time data capabilities make it a go-to choice for businesses and data analysts alike.

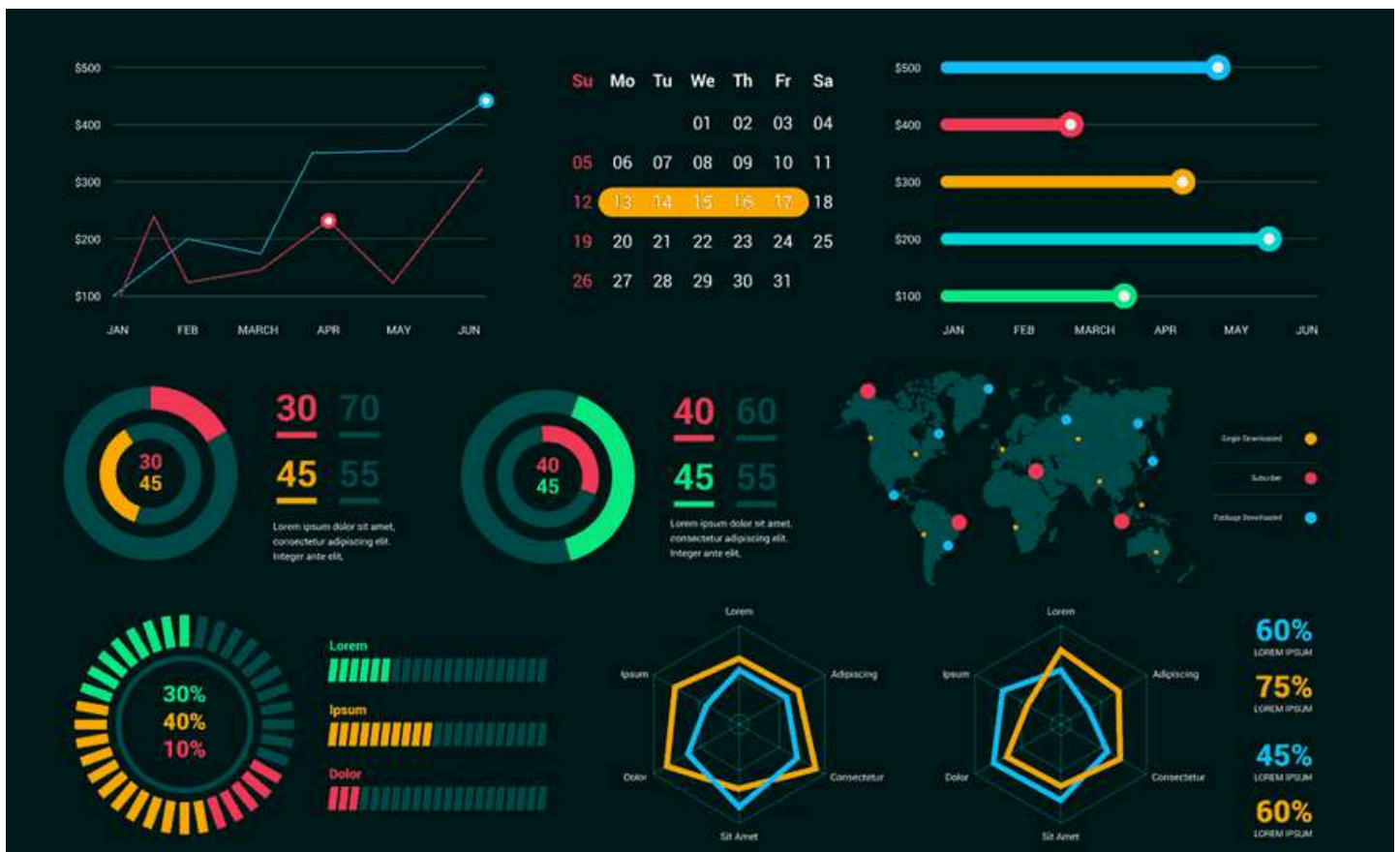

## Pizza Sales Dashboard: A Real-World Use Case

To explore the capabilities of Power BI, I developed a Pizza Sales Analysis Dashboard using a real-world dataset sourced from Kaggle. The data includes detailed records of pizza orders from January to December 2015, capturing metrics such as order quantities, revenue, categories, and sizes.

## Business Insights Extracted:

- **Peak Order Days:** Friday and Saturday evenings saw the highest volume of orders.
- **Top-Performing Months:** July and January experienced maximum sales.
- **Category Performance:** The Classic pizza category contributed the highest revenue and total orders.
- **Size Preference:** Large-size pizzas dominated overall sales, highlighting consumer preference for value-based purchases.
- **Best Sellers:** The Thai Chicken Pizza and Classic Deluxe Pizza led in revenue and quantity sold.
- **Least Performers:** The Brie Carre Pizza ranked lowest across all KPIs—revenue, quantity, and total orders.

## Why Power BI Stands Out

- **User-Friendly Interface:** No-code to low-code design suited for all skill levels.
- **Custom Visualizations:** Offers a variety of charts, graphs, and maps.
- **Real-Time Dashboards:** Connects live data for up-to-date monitoring.
- **Cross-Platform Sharing:** Dashboards can be shared via web, mobile, and cloud platforms for collaborative decision-making.

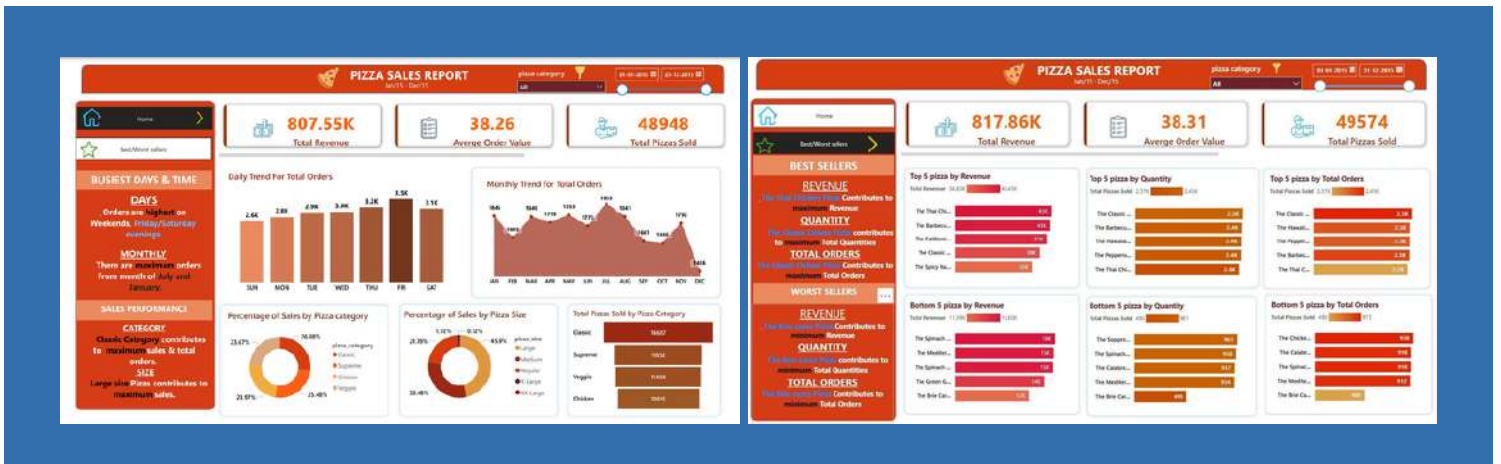

Power BI is more than a visualization tool—it's a platform that empowers users to understand their data. By using Power BI, my Pizza Sales Dashboard project demonstrates how data storytelling can uncover valuable insights, influence marketing strategies, and drive business growth. The dataset used was sourced from Kaggle, further emphasizing the value of open data in real-world applications. Whether for academic projects or enterprise reporting, Power BI proves to be a powerful asset in the modern analytics toolkit.



By  
Dheiveeka Nachiyar P  
I MCA

# FROM THE GROUND TO THE CLOUD: THE FUTURE OF COMPUTING

## What is Cloud Computing?

Cloud computing is the delivery of computing services—like storage, servers, databases, networking, software, and analytics—over the internet (aka “the cloud”). Instead of owning physical hardware or software, you can access everything online, on demand, and pay only for what you use.



Think of cloud computing like renting a house instead of buying one. You get the space and utilities you need, without worrying about building or maintaining it.

## The Future of Cloud Computing: What's Next?

Cloud computing has already transformed how we store, access, and manage data. From streaming our favorite shows to running global businesses, the cloud is everywhere. But what's next? Let's explore the exciting future of cloud computing

### 1. Edge Computing & IoT

The future of the cloud is closer to the user—literally. Edge computing pushes data processing closer to devices, reducing latency and enabling real-time decisions. This is vital for technologies like self-driving cars, smart homes, and industrial IoT systems

### 2. AI & Machine Learning Integration

Cloud platforms are becoming powerhouses for artificial intelligence. Services like AI-as-a-Service and AutoML are making advanced analytics accessible. Businesses are using the cloud to build intelligent applications that learn and improve on their own.

### 3. Rise of Serverless Computing

Serverless architecture is gaining momentum. Developers can now focus on writing code without worrying about infrastructure. It's cost-efficient, automatically scalable, and ideal for modern applications.

### 4. Multi-Cloud & Hybrid Cloud Models

Companies are moving away from relying on a single cloud provider. Instead, they're combining multiple platforms—public, private, and hybrid—for better flexibility, cost control, and resilience.

### 5. Sustainability and Green Cloud

With growing environmental awareness, cloud providers are building energy-efficient data centers. The goal? Reduce carbon footprints and enable “green computing” through smarter resource management.

### 6. Quantum Computing in the Cloud

Though still emerging, cloud-accessible quantum computing could revolutionize areas like cryptography, drug discovery, and logistics. Major cloud providers are already experimenting with quantum services.

### 7. Next-Gen Security

Security remains a top priority. The future brings innovations like confidential computing, zero-trust architecture, and cloud-native firewalls—ensuring data remains safe in a highly connected world.

Cloud computing is evolving beyond storage and scalability. It's becoming the backbone of AI, edge innovation, sustainability, and even quantum breakthroughs. The future is not just about being “on the cloud”—it's about unlocking what the cloud can do next.



# INTERESTING FACTS ABOUT CLOUD COMPUTING

Cloud computing has become an invisible backbone of the internet—and most of us use it every day without even realizing it. Here are 10 fascinating facts about this powerful technology that's changing the way we live, work, and learn:



Think of cloud computing like renting a house instead of buying one. You get the space and utilities you need, without worrying about building or maintaining it.

## 1. The "cloud" isn't floating in the air.

Despite its name, the cloud isn't floating above us. Cloud data is stored in giant physical data centers—massive buildings full of powerful servers—spread across the globe.

## 2. Cloud computing started in the 1960s.

The concept was first proposed by computer scientist John McCarthy, who suggested that computing could be sold like a utility (just like water or electricity).

## 3. Amazon Web Services (AWS) made more money than Amazon's retail business for years.

Amazon Web Services (AWS) has been more profitable than Amazon's online store for years! It holds a massive share of the cloud market and is one of Amazon's biggest money-makers.

## 4. The cloud powers most of what you do online.

Whether you're scrolling through Instagram, watching Netflix, or using Google Docs—you're using the cloud. Modern apps and services rely on cloud infrastructure to work.

### 5. Cloud data is safer than most local storage.

Major cloud providers invest millions in cybersecurity, including encryption, access controls, and 24/7 monitoring.

### 6. Over 90% of companies use cloud services.

From small startups to global tech giants, cloud computing has become essential for scaling, saving costs, and boosting productivity.

### 7. Green cloud is a growing trend.

Tech companies are focusing on eco-friendly data centers. Google and Microsoft are building carbon-neutral or even carbon-negative cloud infrastructure to reduce environmental impact.

### 8. Serverless computing is a thing.

You can run code in the cloud without managing servers at all. The system spins up servers for you only when needed—and shuts them down automatically.

### 9. Cloud jobs are in high demand.

Cloud certifications in AWS, Azure, and Google Cloud are some of the most valuable in the job market today. Learning these can boost your career in IT and software development.

### 10. Even NASA uses the cloud.

NASA relies on cloud computing to store and analyze massive datasets from space missions, satellites, and telescopes—helping scientists explore the universe.



# CAMPUSFEST: A SMART SOLUTION FOR COLLEGE EVENT ENGAGEMENT

CampusFest is an Android-based mobile application developed as a mini project for Mobile Application Development. It aims to simplify how college students discover and participate in events like cultural fests, seminars, and competitions. Often, students miss out on events due to lack of timely information or complex registration processes. CampusFest solves this by offering a centralized platform for event discovery and registration. The app is built using Android Studio with Java, focusing on usability and efficiency. It enhances student engagement and fosters a more connected college community.



# CampusFest

Mini Project for Mobile Application Development using Android Studio

Imagine being a college student eager to participate in cultural festivals, technical seminars, or inter-college competitions—only to miss out due to late updates or tedious registration processes. Recognizing this common challenge, our team set out to create a solution that makes student life more connected and vibrant. The result is CampusFest, a user-friendly Android application that redefines how students discover, register for, and share college events.

Our logo is more than just a symbol — it tells the story of what CampusFest stands for. At the center, you'll see a location pin, representing how the app helps students discover events happening across different colleges. It shows that no matter where the event is, CampusFest helps you find it easily. On top of the pin sits a graduation cap, a universal symbol of students, learning, and college life. This highlights that the app is specially designed for college students.

CampusFest is designed to serve as a centralized hub for all college-related activities, allowing students to explore a wide range of events happening in and around their campuses. Whether it's a cultural fest, a coding marathon, or a workshop on AI, CampusFest brings everything together in one place.

### Key Features:

- **Event Discovery & Registration:** Students can browse through upcoming events and register instantly, removing the friction from the participation process.
- **User-Generated Events:** The app empowers students and organizers to add new events directly, ensuring the platform stays current and community-driven.
- **Centralized Event Management:** By consolidating event details into a single platform, CampusFest eliminates the chaos of scattered posters, emails, and WhatsApp groups.

Built using Android Studio with Java, the app emphasizes a clean UI and smooth functionality, demonstrating practical implementation of core mobile development concepts. More than just a technical achievement, CampusFest encourages inter-college collaboration and fosters an engaging campus culture. With this project, we've not only addressed a real-world student need but also gained hands-on experience in building scalable Android applications. CampusFest stands as a testament to how technology can simplify and enrich student life—one event at a time.

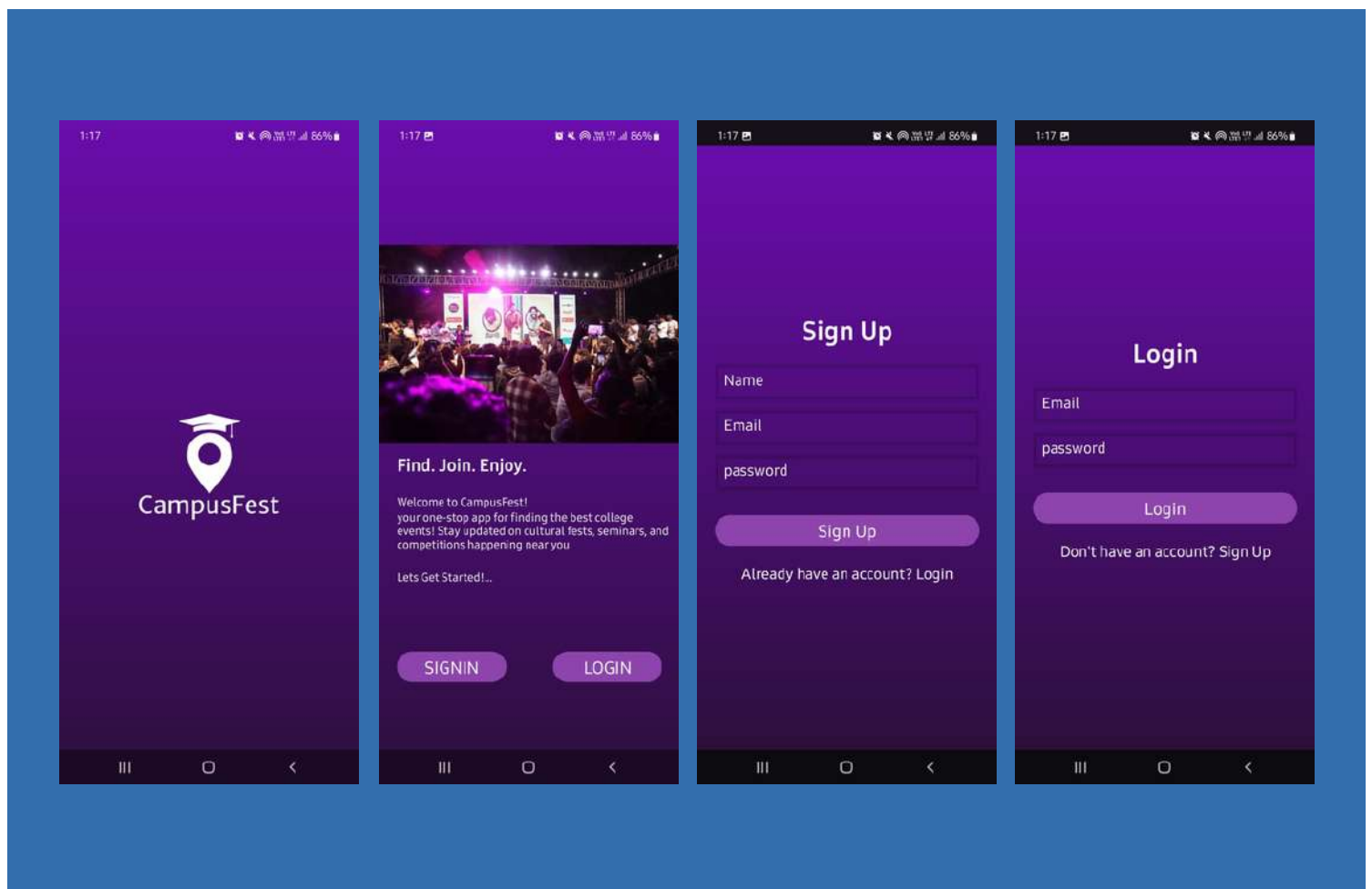

In addition to its core functions, CampusFest offers several thoughtful features to enhance the overall user experience. With Map Navigation, students can easily locate event venues across various campuses, saving time and reducing confusion. The Upcoming Events section gives users a clear view of what's ahead, helping them plan their schedules in advance. After attending an event, users can also leave Ratings and Reviews, offering feedback and helping others make informed decisions about future events. These added functionalities create a more interactive, organized, and community-focused platform.

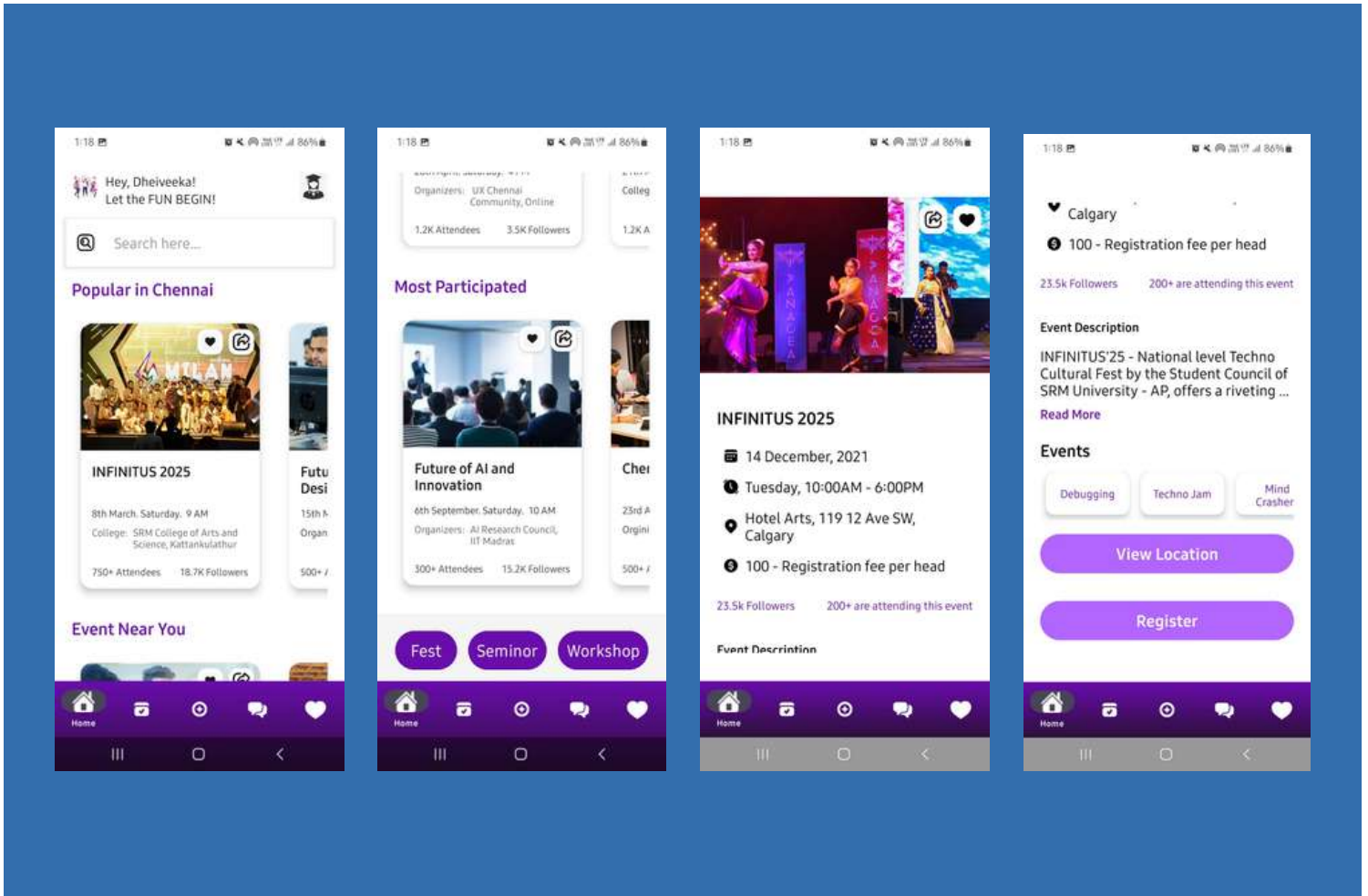

CampusFest revolutionizes the way students engage with college events by providing a centralized, user-friendly platform for discovering, registering, and sharing events effortlessly. By eliminating the challenges of scattered information and last-minute discoveries, it fosters greater participation and collaboration among students from different institutions. With its intuitive design and real-time event updates, CampusFest enhances the overall college experience, making cultural festivals, tech seminars, and competitions more accessible than ever.

CampusFest is more than just an event listing app—it's a complete solution designed to improve how students engage with college activities. By centralizing information and simplifying registration, it eliminates the common barriers students face. Features like map navigation, upcoming event previews, and post-event feedback make the experience smoother and more interactive. The app empowers students to not only attend events but also create and share them, encouraging a vibrant campus culture. From a development perspective, this project helped us apply core concepts of Android development in a real-world scenario. It challenged us to think about user experience, data flow, and functionality in a practical way. CampusFest reflects the potential of mobile technology to solve everyday problems in student life. With further development, it can evolve into a platform used across colleges nationwide. We're proud of what we've built and excited about its future potential.

By  
 Lakshmi Pratha S  
 Dheiveeka Nachiyar p  
 I MCA

# BEYOND THE AESTHETIC: THE DARK SIDE OF THE GIBLI AI TREND

## Studio Ghibli Isn't Just a Style – It's a Legacy

Studio Ghibli isn't just about soft colors and big-eyed characters. It's one of the most respected animation studios in the world. Movies like *Spirited Away*, *My Neighbor Totoro*, and *Princess Mononoke* are known not just for how they look, but for how they make people feel.

These films take years to create. Every frame is drawn by hand. There's emotion, detail, and a deep connection to nature and human life in each scene. This kind of work is rare, and it comes from real people—artists—who spend countless hours bringing it to life.

## What's the Ghibli AI Trend?

Recently, a new AI image generator by OpenAI went viral. It can turn selfies and photos into “Ghibli-style” images. People have been uploading their faces and turning them into dreamy anime versions of themselves. At first, it seems fun and harmless. But many artists and fans of Studio Ghibli are deeply upset. and for good reason.



Praise the art, but celebrate the artist.

## A Studio Built on Passion and Patience

Studio Ghibli, founded by the legendary animator Hayao Miyazaki, is known worldwide for creating breathtaking animated films like *Spirited Away*, *My Neighbor Totoro*, and *Grave of the Fireflies*. These movies aren't just entertainment—they are hand-crafted pieces of cinematic art.

Every frame is drawn with love, care, and incredible effort. It takes years to make just one Ghibli film. Artists sketch each scene by hand. Animators paint every expression, movement, and background. No shortcuts—just pure dedication.

Miyazaki once said:

“We don't make movies to make money. We make them because we love animation.”

## Enter AI: Fast, Easy, and... Unfair?

Recently, OpenAI and other platforms introduced image generators that can create Ghibli-style artwork in minutes. People upload selfies or photos, and the tool instantly turns them into what looks like a scene from a Ghibli film.

It looks magical—but it raises a big question:

Is it okay for a machine to imitate years of human effort in seconds?

AI doesn't understand beauty, culture, or storytelling. It learns from patterns, by analyzing thousands (or millions) of real artworks on the internet. This includes styles created by human artists—often without their permission.

So when people post AI-generated “Ghibli portraits,” they are enjoying the style of Ghibli but not celebrating the hard work of the artists who built it.

## How AI Really Works?

AI tools like these use something called machine learning, especially a type called Generative AI. Here's a simple way to understand it:

1. The AI is trained on a large number of images—real artworks, movie scenes, illustrations, etc.
2. It looks for patterns: how colors blend, how faces look, how Ghibli art uses lines and shapes.
3. After learning these styles, the AI can generate a new image that looks similar—but it's not actually “created” in the human sense. It's just remixing data.

This raises ethical concerns. Is it fair to borrow from thousands of artists to make something without giving credit or permission?

## Artists vs. Algorithms

Hayao Miyazaki, the creator of Studio Ghibli, called AI-generated art “an insult to life itself.” He believes true art comes from human emotions, not algorithms. It's disheartening for artists to see their work mimicked by machines

### What Would Hayao Miyazaki Say?

Hayao Miyazaki, one of the founders of Studio Ghibli, has always been against AI in art. He once said:

“I strongly feel that this is an insult to life itself.”

To him, art is meant to come from real human experiences—from love, pain, joy, and imagination. It's not something a machine can understand, let alone create.

So when people use AI to copy his studio's style in just seconds, it goes against everything he believes in. It feels like a shortcut—like skipping all the effort and heart that real artists put in.

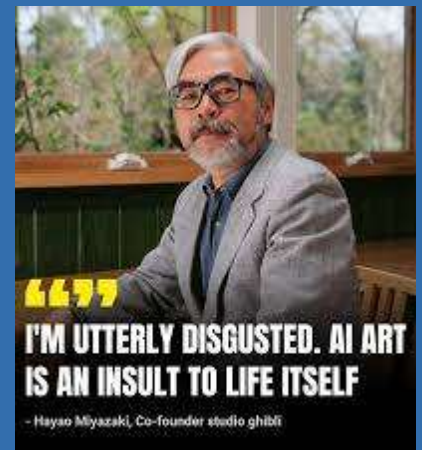

## Is This Really Just for Fun?

Sure, using these AI filters might feel like harmless fun. But there's a bigger issue here.

Every time you upload your photo to use a trend like this, companies like OpenAI might save your images. They use them to train their models. That means your personal photos could be used in ways you didn't expect. Also, these trends make it easier for people to ignore real artists, and instead rely on machines to make “pretty pictures” fast and free. This is unfair to those who have spent years learning, improving, and creating art with care.

### Hidden Risks Behind the Trend

When people upload their photos to use these AI tools, they often don't realize that their data might be collected and stored. These photos can be used to improve AI models—without clear permission.

This raises important privacy questions:

- Who owns the image you upload?
- How will that image be used in the future?
- Can it be misused?
- the AI is learning to copy human art styles, including Ghibli's, without actually understanding the emotions or stories behind them.

### Why It Hurts Real Art

AI can copy how something looks. But it can't copy the feelings behind it. The Ghibli-style images from AI look nice on the outside, but they don't have the same soul or meaning as the real thing.

Using AI like this reduces deep, meaningful art into a filter for social media likes. It's not celebrating the beauty of Ghibli—it's taking it out of context and using it for fun without respect.

### What We Can Learn as Tech Students

As future engineers and developers, we're entering a world where AI will play a big role. But with great power comes great responsibility.

We must build technology that:

- Respects creativity
- Protects privacy
- Supports original thinkers, not replaces them



Studio Ghibli films have inspired people all over the world. But they were made with love, effort, and deep meaning. Turning that into a quick AI trend takes away the heart of it all.

Let's enjoy art, but also respect the people who make it. Don't let machines erase the beauty of human creativity. **“Praise the art, but celebrate the artist.”**

By  
Lakshmi Pratha S  
I MCA

# CHATGPT IN EDUCATION: A POWERFUL PARTNER FOR MODERN LEARNING

In today's fast-paced digital world, technology plays a major role in transforming the way we learn, work, and communicate. One such groundbreaking innovation is ChatGPT, developed by OpenAI—a highly advanced AI language model that is changing how students, educators, and professionals approach everyday learning and productivity.

## What Is ChatGPT?

ChatGPT uses Natural Language Processing (NLP) to understand and generate human-like responses to written prompts. This means you can ask it a question—about anything from Shakespeare to Python programming—and it will reply with a well-structured, easy-to-understand answer in just seconds.

Whether you're stuck on a tricky math problem, struggling to write an assignment, or exploring a new topic, ChatGPT is like a virtual study buddy that's available 24/7.



"Technology is best when it brings people together." — Matt Mullenweg

## How Students Can Benefit

Here's how ChatGPT can support learning in smart and helpful ways:

- **Instant Feedback:** Stuck on an essay or a piece of code? ChatGPT can suggest improvements or point out errors in real time.
- **Simplifying Complex Topics:** Whether it's quantum physics or database normalization, ChatGPT breaks things down into simpler explanations.
- **Brainstorming Help:** Need a title, topic ideas, or outlines for a presentation? Just ask.
- **Language Support:** ChatGPT can help with grammar, sentence structure, and even translation for multilingual learners.
- **Quick Clarifications:** Get instant answers to your doubts without waiting for someone to reply.

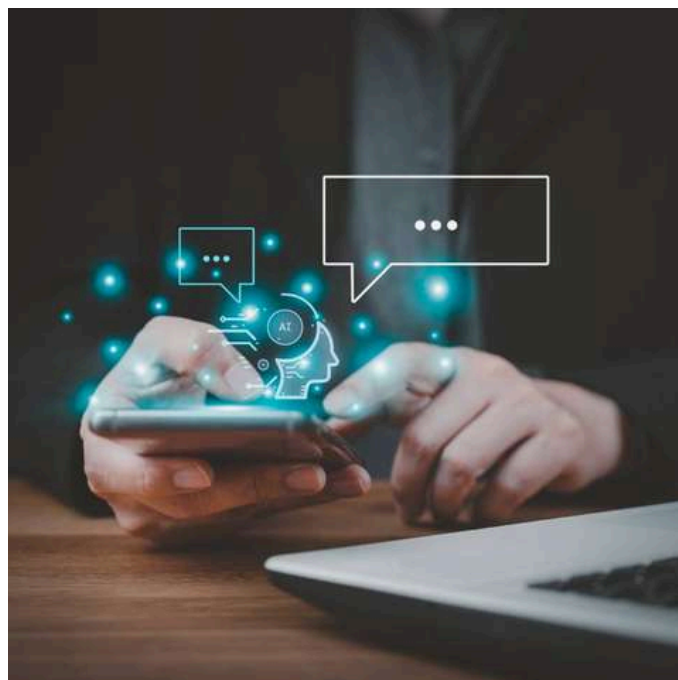

## How Educators Can Use ChatGPT

It's not just for students! Teachers and professors can also benefit:

- Generate quiz questions and answer keys
- Design lesson plans or worksheets
- Explore different ways to explain tricky concepts
- Support diverse learning styles with varied content formats
- With the right guidance, ChatGPT can become a helpful co-teacher in the classroom.

## But There Are Limits...

As smart as ChatGPT is, it's not perfect. Here are a few things to keep in mind:

- It can give outdated or inaccurate information. Always cross-check facts, especially when doing research.
- It lacks real-world experience. ChatGPT doesn't understand emotions or context the way humans do.
- It can't replace creativity and critical thinking. Original ideas and human judgment are still your best tools for success.
- In short, ChatGPT is best used as a supplement—not a substitute—for learning.

## A Tool, Not a Crutch

Like calculators in math or Google in research, ChatGPT is a powerful tool. But it's up to us to use it wisely and ethically. Use it to understand, not just to copy. Let it assist your learning, not do all the work.

ChatGPT stands at the frontier of AI innovation, offering exciting opportunities in education, creativity, and problem-solving. Its ability to generate thoughtful responses makes it a valuable companion for both academic and personal growth.

As students of the digital age, learning to work with AI rather than fear it could be one of the most important skills of our time.

# THE ROLE OF ETHICAL HACKING IN SAFEGUARDING THE DIGITAL WORLD

In today's hyperconnected world, where data breaches and cyberattacks are on the rise, the role of ethical hackers has never been more critical.

## What is Ethical Hacking?

Ethical hacking is the process of legally and safely breaking into computers, networks, or digital systems to test how secure they are. These ethical hackers, also known as “white-hat” hackers, work with permission and use their skills to improve security instead of causing harm.

## Ethical Hackers vs. Black-Hat Hackers

While ethical hackers work to protect and secure data, black-hat hackers do the opposite. Black-hat hackers break into systems illegally with bad intentions—stealing data, spreading viruses, or damaging systems. Their goal is usually personal gain or disruption. Ethical hackers, on the other hand, use similar skills but with honest intentions. They are often hired by companies to test security and suggest improvements. The key difference is intent: black hats break the law, while white hats follow it.



It takes a hacker to stop a hacker—ethically

## Why is Ethical Hacking Important?

- **Prevention of cyberattacks:** Ethical hackers help organizations identify vulnerabilities before malicious hackers can exploit them.
- **Protection of sensitive data:** By simulating attacks, they ensure that personal, financial, and confidential information remains safe.
- **Compliance and trust:** Many industries require regular security assessments, and ethical hacking plays a key role in meeting those standards.

## What is Ethical Hacking?

1. **Penetration Testing** – Simulate real attacks to see how secure a system is.
2. **Vulnerability Assessment** – Scan systems to find weaknesses.
3. **Social Engineering** – Test if people fall for phishing scams or share passwords.
4. **Security Audits** – Check if a company follows good cybersecurity practices.

In a world where cyber threats are growing every day, ethical hacking has become one of the most important tools for protecting digital systems. Ethical hackers use their skills not to harm, but to help organizations find and fix security weaknesses before malicious hackers can exploit them. By thinking like attackers but acting with responsibility and permission, they play a key role in keeping sensitive data safe and secure. Their work builds trust, ensures compliance with security standards, and strengthens overall digital defenses. These professionals are not just skilled tech experts—they are digital protectors working for the greater good. With the rise in online services, remote work, and digital banking, the need for ethical hackers has never been greater. They remind us that cybersecurity is not just about strong passwords and firewalls, but also about ethical minds who understand systems deeply. Ethical hacking combines intelligence with integrity, proving that technology in the right hands can protect rather than destroy. In essence, ethical hackers don't break the system—they make it stronger.



By  
Hansika Priya A A  
I MCA

# THE RISE OF ARTIFICIAL INTELLIGENCE IN DAILY LIFE

## Exploring how AI is transforming the world around us

Artificial Intelligence (AI) is no longer just a theme in sci-fi movies—it's a part of our everyday lives. From waking up with a “Good Morning” from Alexa to binge-watching Netflix shows recommended by an algorithm, AI is quietly working behind the scenes to make our digital experiences smoother, smarter, and more personalized.

It powers virtual assistants, automates repetitive tasks, and improves decision-making in everything from healthcare to finance. AI is revolutionizing industries by enabling automation, boosting productivity, and even predicting trends. It's becoming an essential tool in education, assisting students with homework and making learning more interactive. As AI continues to evolve, it promises to shape not only our digital experiences but also the way we work, live, and interact with the world.

## AI Across Industries

- Automation in manufacturing to increase efficiency and reduce errors
- Customer support with AI chatbots offering 24/7 assistance
- Data analysis for smarter, faster business decisions
- Healthcare diagnostics using AI imaging and pattern recognition
- Cybersecurity systems that detect threats quicker than human analysts
- Smart homes and self-driving cars powered by AI and machine learning

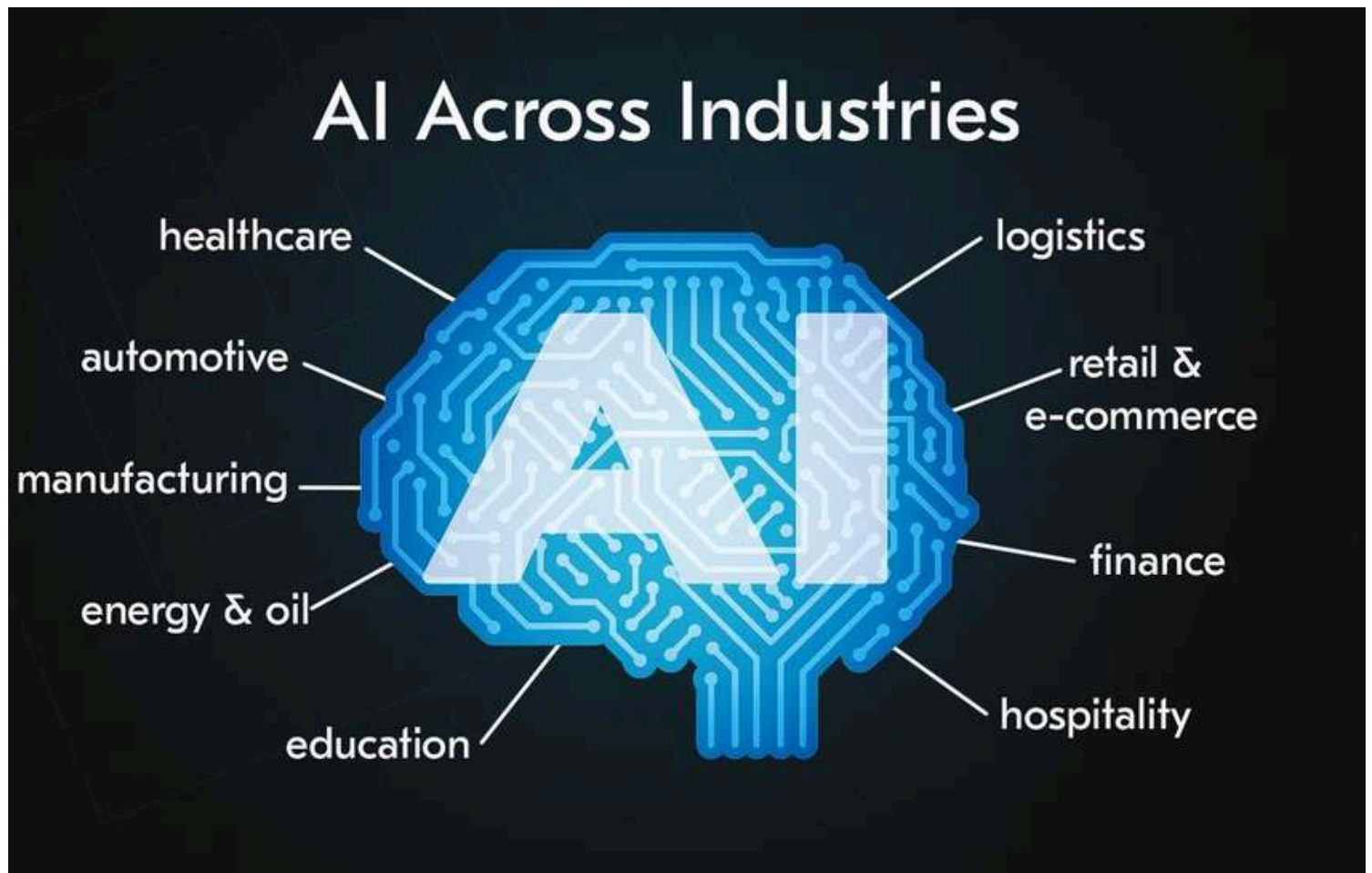

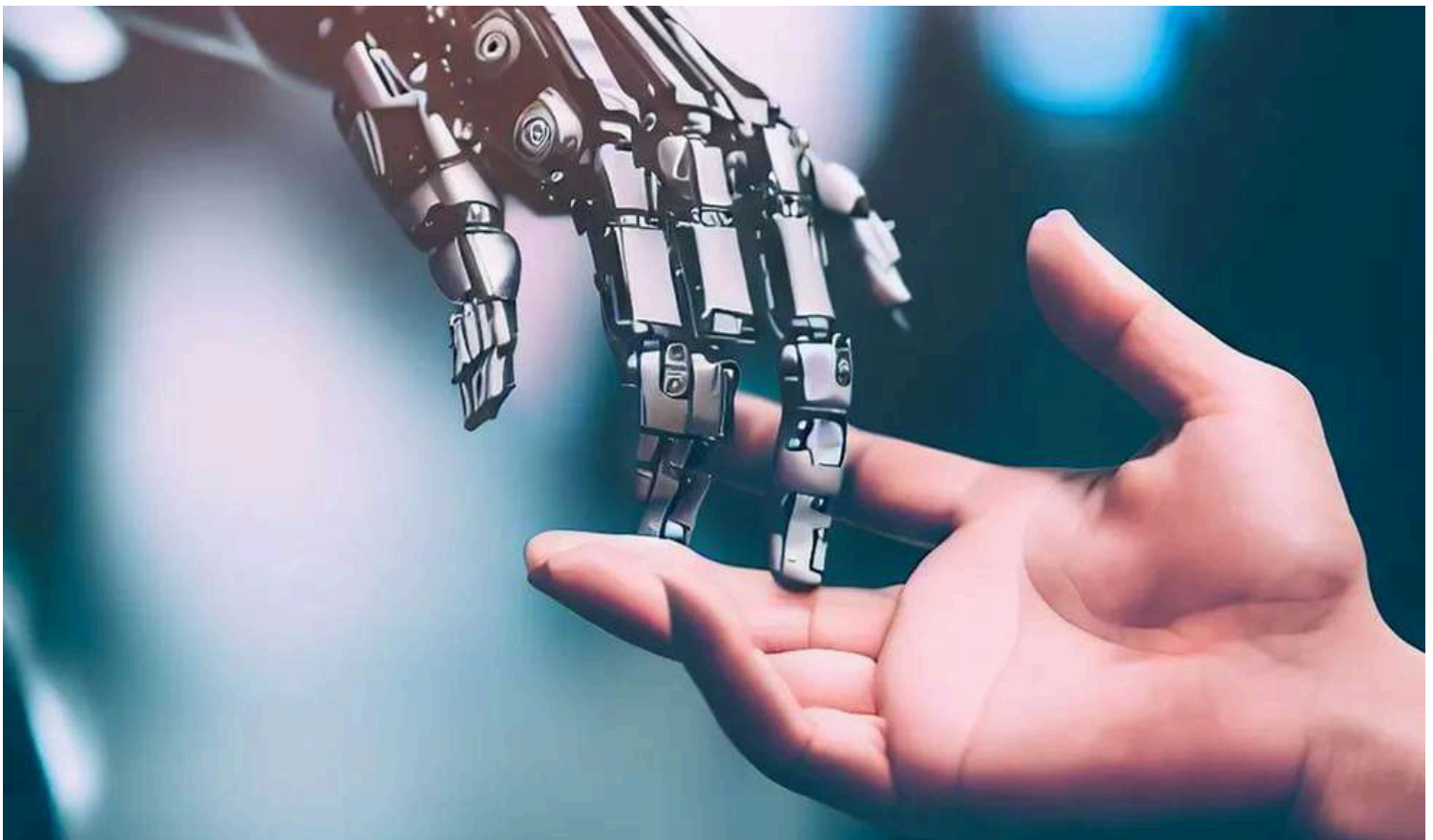

Don't just use technology—learn to build it.

### **Ethical Concerns and the Need for Responsibility**

With great power comes great responsibility. As AI spreads, we must also think about:

- **Data privacy:** Who owns the data we share?
- **Job displacement:** Will automation replace certain careers?
- **Algorithmic bias:** Can AI be unfair or discriminatory?
- **Transparency:** How do these systems make decisions?
- Governments, developers, and users must work together to ensure that AI is used ethically and responsibly.

### **Opportunities for Students**

For MCA students and tech enthusiasts, this is the best time to learn about AI. Understanding how it works—and how to build it—can lead to exciting careers in:

- AI/ML Development
- Data Science
- Robotics
- Cybersecurity
- Software Engineering
- Ethical AI Research

By  
Vinothini J A  
I MCA

# SWOT ANALYSIS OF FIGMA: A TOOL EVERY DESIGNER AND DEVELOPER SHOULD KNOW

Figma is a leading cloud-based design and collaboration platform, essential for UI/UX, product design, and web development. This poster presents a comprehensive visual SWOT analysis—highlighting Figma’s strengths, weaknesses, opportunities, and threats—to give you clear insight into its role and impact in today’s fast-evolving design landscape.

The poster features a dark blue background with a large, stylized yellow sunburst behind the word 'SWOT' in white. Below the title, four horizontal panels are arranged vertically, each with a distinct color and iconography. The 'STRENGTHS' panel is light green and shows a group of diverse people. The 'WEAKNESS' panel is light purple and shows people working at computers. The 'OPPORTUNITIES' panel is light yellow and shows people interacting with a large screen. The 'THREATS' panel is light blue and shows people in a meeting. At the bottom, a white text box contains a summary statement.

**SWOT ANALYSIS FOR FIGMA**

# SWOT

**STRENGTHS**

- Intuitive Interface & Learning Curve
- Cross-Platform Accessibility
- Cloud-Based Collaboration

**WEAKNESS**

- Pricing for Teams
- Limited Advanced Prototyping
- Dependent on Internet Access

**OPPORTUNITIES**

- Educational Partnerships
- Increased Remote Work Adoption
- AI Integration

**THREATS**

- Rising Competition
- Feature Parity Catch-Up
- Security Concerns

SWOT ANALYSIS HELPS IN UNDERSTANDING THE CURRENT POSITION AND FORMULATING STRATEGIES FOR GROWTH AND SUCCESS.

By  
Chivaraam A  
I MCA

# ART: BY SOUL OR SCRIPT?

This AI-generated poster designed created in seconds—to highlight both AI’s power and its limits. It contrasts a human designer pouring emotion into their craft with an AI system producing similar work in seconds. As technology evolves, it challenges us to ask: Are we sacrificing the soul of creativity for speed and convenience?

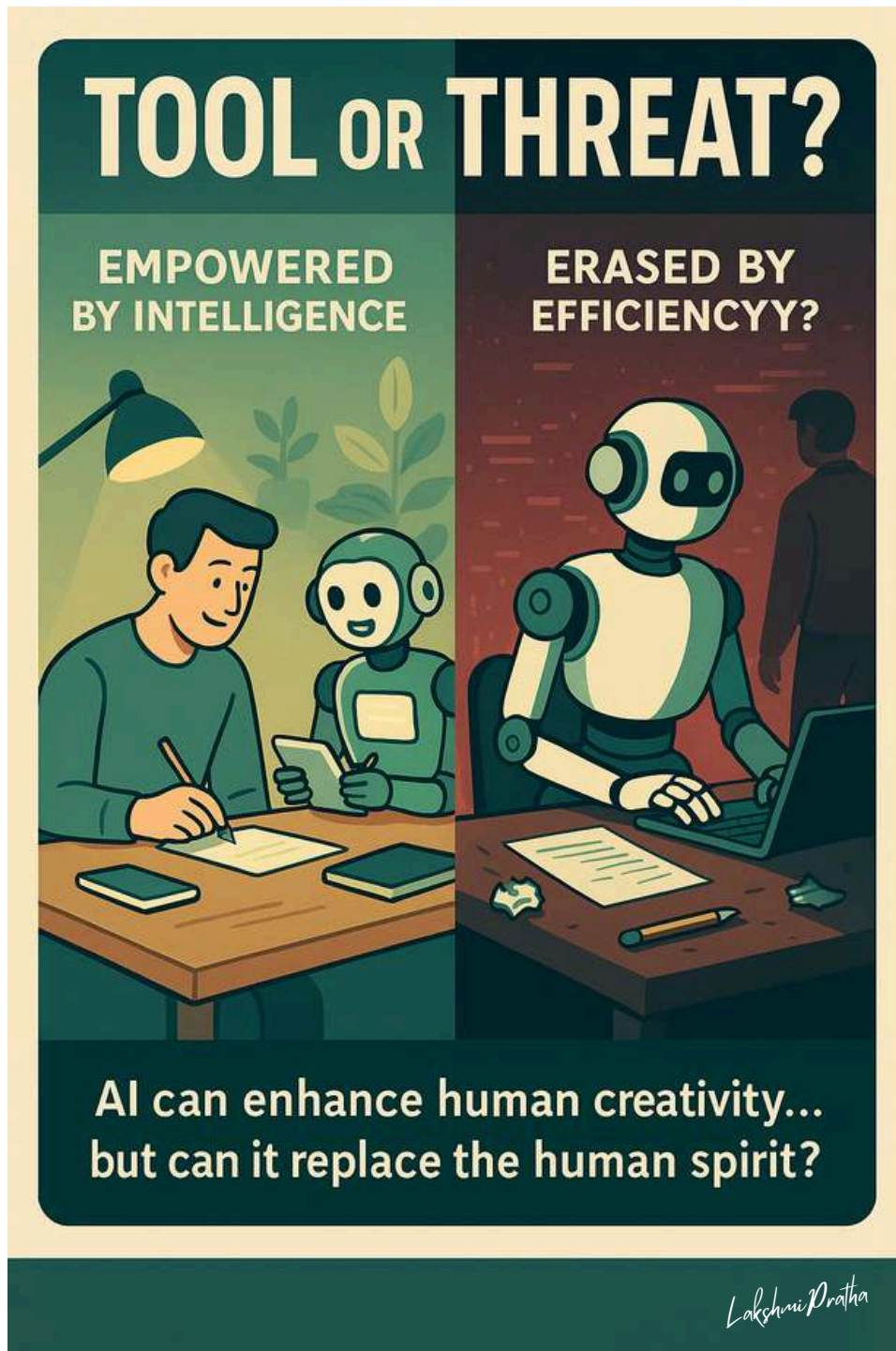

By  
Lakshmi Pratha S  
I MCA